

# Darwis\_2021\_IOP\_Conf.\_Ser. \_Earth\_Environ.\_Sci.\_926\_01202

8

*by* Turnitin Indonesia

---

**Submission date:** 01-Aug-2022 09:35AM (UTC+0800)

**Submission ID:** 1877428788

**File name:** Darwis\_2021\_IOP\_Conf.\_Ser.\_Earth\_Environ.\_Sci.\_926\_012028.pdf (1M)

**Word count:** 3115

**Character count:** 14260

**PAPER · OPEN ACCESS**

## Study of power flow in electricity system using extreme learning machine

<sup>1</sup>  
To cite this article: M Darwis *et al* 2021 *IOP Conf. Ser.: Earth Environ. Sci.* **926** 012028

<sup>1</sup>  
View the [article online](#) for updates and enhancements.

### You may also like

- [Landslide Early Warning Model Based on the Coupling of Limit Learning Machine and Entropy Method](#)  
Ning Zhang, Qing Li, Chuangjiang Li et al.
- [11 comparison between extreme learning machine and artificial neural network-back propagation for predicting the dengue incidences number in DKI Jakarta](#)  
S Tiffany, D Sarwinda, B D Handari et al.
- [Sediment-carrying capacity prediction using extreme learning machine](#) <sup>1</sup>  
Xianglong Wei, Chang Li, Wei Huang et al.

# Study of power flow in electricity system using extreme learning machine

M Darwis<sup>1,2\*</sup>, I C Gunadin<sup>1</sup> and S M Said<sup>1</sup>

<sup>1</sup>Department of Electrical Engineering, University of Hasanuddin, Indonesia

<sup>2</sup>Electrical Engineering Study Program, University of Hasanuddin, Indonesia

\*E-mail: muhdarwis1979@gmail.com

**Abstract.** Load Flow or Power Flow Analysis in the power system is used to determine the power system parameters such as voltage, current, active power, and reactive power contained in the power grid. The method that has long been used in the calculation of load flow or power flow is the Newton-Raphson iteration method. As for its development, to complete the power flow study, it is carried out by implementing the Artificial Intelligence method, one of which is the Extreme Learning Machine method. This method is used in the simulation of the simple 39 Bus system calculation from IEEE. In this Extreme Learning Machine, the testing analysis is carried out with 2 inputs, 1 hidden layer, 5 neurons, and 2 outputs and the number of datasets is 39 to produce MAE and MAPE respectively 2.02 and 0.76% and with a very fast processing time of 0.010s

## 1. Introduction

The need for electricity continues to increase over time. This results in the design of the electrical network system configuration must always be able to adjust to the loading conditions so that it is necessary to carry out a power flow study. A power flow study is a study that reveals the performance and power flow (real and reactive) for a certain state when the system is working at a steady state. The main purpose of the power flow study is to determine the magnitude or magnitude of the voltage, the voltage angle/vector, the flow of active power and reactive power, and power losses [1].

### 1.1. Power Flow Calculation Method

There are many methods of calculating the flow of power, one of which is the Newton Raphson Method. The Newton Raphson method is based on the Newton-Raphson algorithm for solving simultaneous quadratic equations of power networks. [2] This made this method the most widely used until the Artificial Intelligence (AI) method emerged. One of the results of the development of the AI method is the Extreme Learning Machine learning method that can challenge power flow problems precisely, accuracy in calculations, and real-time.

### 1.2. Extreme Learning Machine

Extreme Learning Machine (ELM) is a feedforward neural network with a single hidden layer or commonly known as Single Hidden Layer Feedforward Neural Networks (SLFNs). [3] The ELM learning method is designed to overcome the weaknesses of the neural network, especially in terms of learning speed. ELM parameters such as input weight and hidden bias are chosen randomly so that the learning speed is faster and results in good generalization performance. ELM mathematical model is simpler and more effective than feedforward neural network so that it can quickly solve electrical power flow problems [4]



15

### 1.3. Artificial Neural Network

An Artificial Neural Network is a small processing unit or processor that resembles a neural network system in humans called neurons. ANN has an adaptive characteristic that allows input-output mapping estimates to find patterns in the data and pass them again over the network to modify its parameters. [5] Extreme Learning Machine is one of the learning methods on Artificial Neural Networks that has a higher level of accuracy and speed than other methods. The weakness of ANN is that it is not optimal to determine the hidden node parameters manually so it must be combined with other methods [6]. This is because the ANN structure is quite complicated where data must pass through many layers of nodes.

### 1.4. Related Works

One of the studies related to Extreme Learning Machines was carried out by Gunadin et al [7], namely the use of Extreme Machine Learning to overcome the problem of voltage instability or the phenomenon of stress failure. This method was tested on an IEEE 14 bus and a Java-Bali system. In determining the value of the bus participation factor for each bus load using the modal analysis method. The ELM will then be used to make predictions based on the input data of generator bus voltage, generator active and reactive power, the four largest values of participation factor, and changes in power on the load bus. In this paper, the estimation results obtained by ELM can predict the voltage stability condition in the electric power system accurately by predicting the weakest bus in the electric power system.

## 2. Power Flow Studies

The study of the flow of power in the electric power system is an important study. A power flow study is a study that reveals the performance and power flow (real and reactive) for a certain state when the system is working at a steady state. The main purpose of the power flow study is to determine the voltage magnitude, voltage angle/vector, active power flow and reactive power in the line, and power losses that appear in the power system.

In the concept of Power Flow Calculation In solving (computation) of a flow of power, the system is operated in steady and balanced conditions. Each bus in an electric power system has active power  $P$ , reactive power  $Q$ , voltage magnitude  $|V|$ , and voltage phase angle  $\Theta$ . So for, every bus has four quantities, namely  $P$ ,  $Q$ ,  $|V|$ , and  $\Theta$ . In a power flow study, two of the four quantities are known and the other two needs to be searched for. Based on the foregoing, the buses are divided into three types, namely load buses, generator buses, and swing buses/reference buses (slack buses) [8].

## 3. Load Flow Forecasting Methodology

Implementation data is data from the IEEE 39 Bus. Several criteria/parameters are added to support the computation in order to produce accurate values quickly and precisely. The implementation of output constraints on power flow according to the standard voltage + 5%. The computation process uses Matlab 2017 software to run Extreme Learning Machine. The process diagram of Extreme Learning Machine Method shown in Figure 1 [9].

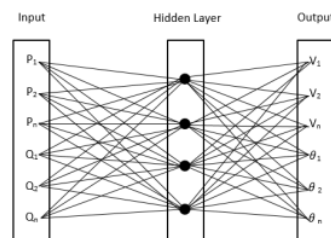

Figure 1. ELM Method Process Diagram.

### 3.1. Training ELM

The steps taken for training using the ELM method are as follows:

- Determine the weight  $W$  and bias randomly.
- Calculate the output matrix in the hidden layer using Equation 1.

$$H = \frac{1}{1 + \exp(-X \text{training} + WT + \text{ones}(N_{\text{train}}, 1) * \text{bias})} \quad (1)$$

Where  $X$  is the training data matrix while  $W^T$  is the transpose weight matrix.

- Calculate the Moore-Penrose Generalized Inverse matrix using Equation 2.

$$H^+ = (H^T \cdot H)^{-1} \cdot H^T \quad (2)$$

$H^+$  is the Moore-Penrose Generalized Inverse matrix of the  $H$  matrix. Meanwhile, the  $H$  matrix is a matrix composed of the output of each hidden layer. Whereas  $Y$  is the target matrix.

- Calculate the output weight matrix of the hidden layer using Equation 3 [10].

$$\beta^i = H^+ \cdot Y \quad (3)$$

### 3.2. Extreme learning machine simulation process

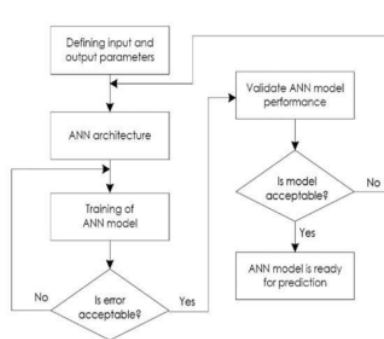

Figure 2. Simulation Process of ELM Method

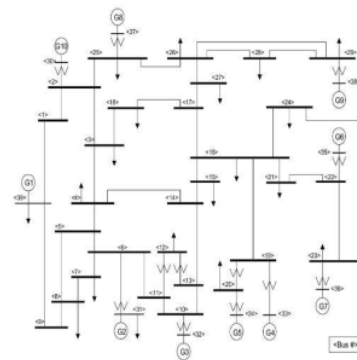

Figure 3. IEEE 39-Bus Network. [11]

The object of research for the calculation of power flow carried out in this study was carried out on the IEEE 39-Bus Network which consists of 39 buses as in Figure 3.

### 3.3. Description of ELM method flowchart stages

The following is a description of the flow chart stages with ELM model according to Figure 2:

- Input data, enter input data on active power and reactive power ( $P$  and  $Q$ ).
- Creating an ELM Neural Network Architecture.
- Perform the ELM method data training process.
- If it meets the requirements of the ELM method, a validation process is carried out.
- Whether the model is accepted from the validation results, if it is continued to the next process
- The output values are  $V$  (Voltage) and  $\Theta$  (Phase Angle).

## 4. Results and Analysis

Program testing is carried out using two methods, namely Extreme Learning Machine Algorithm and Genetic Algorithm. The test results are obtained by entering the same parameters in both methods, namely

the number of Neurons = 5, the number of Hidden Layers = 1, the number of Inputs = 2, the number of Outputs = 2, as for the software used to create programs using Matlab software. The program test results are presented in Table 1 and the comparison of the power flow forecasting results with the actual or actual data from the power flow on the bus is shown in Figure 4. and Figure 5.

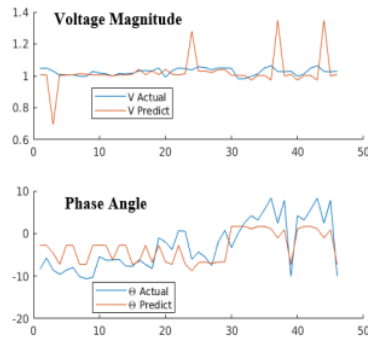

**Figure 4.** Graph of Power Flow Forecasting Results on Bus Using the Extreme Learning Machine method.

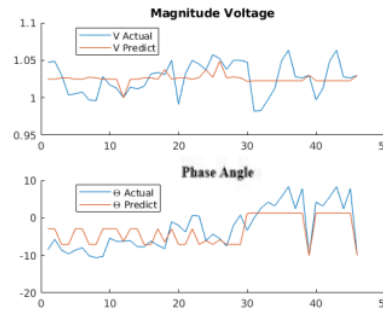

**Figure 5.** Graph of Power Flow Forecasting Results on Bus Using the Artificial Neural Network method.

Based on the comparison graph between ELM and ANN shown in Figure 6. And Figure 7. We can see that the results of forecasting the power flow on the bus show that the value obtained with the Extreme Learning Machine Algorithm is greater than the value obtained in the Genetic Algorithm, although the difference in the values obtained in the two the method difference is very small. This is influenced by the computational speed of both methods, where ELM is much faster than ANN.

#### 4.1. Forecast accuracy

To evaluate the accuracy value, numerical calculations are used MAE and MAPE. Mean Absolute Error (MAE) is a method that can be used to measure the accuracy of the forecasting model. MAE value shows the average absolute error between the forecast/prediction results and the real value. [12] The MAE value will always be positive, the expected difference (error) is of course the smallest error. The MAE value is often used to compare two models in forecasting where the smaller the MAE value, the better the model is in forecasting. Meanwhile, for MAPE (Mean Absolute Percentage Error), MAPE that is below 10% is considered a very accurate forecast. In fact, MAPE between 10-20% is considered good. MAPE between 20-50% is interpreted as a reasonable (feasible) forecast. And a MAPE of more than 50% is considered inaccurate [13]. The MAE and MAPE values for the Extreme Learning Machine and Artificial Neural Network methods according to Figure 4. are 2.02 and 0.76% for ELM and 1.03 and 0.60% for ANN, respectively.

#### 4.2. Performance testing

In the performance tests verify that the system meets specific performance efficiency objectives. Performance testing can measure and report on data as input or output rates, average database query response time and CPU utilization rates. [14] Addition to testing the accuracy value, this study also tested the computational speed performance of algorithm or method used. There are two methods, namely Extreme Learning Machine and Artificial Neural Network. Performance refers to the program execution speed of Extreme Learning Machine which is faster than Artificial Neural Network where the execution speed of Extreme Machine Learning programs is 0.010 seconds while Artificial Neural Network is 0.500 seconds.

**Table 1.** Power Flow Forecasting Results on the Bus using the Extreme Learning Machine method.

Bus	V Actual	V Predict ELM	V Predict ANN	Θ Actual	Θ Predict ELM	Θ Predict ANN
1	1.0474	1.0247	1.0502	-8.44	-2.9278	-6.5778
2	1.0487	1.0247	1.0502	-5.75	-2.9278	-6.5778
3	1.0302	1.0266	1.0361	-8.60	-7.1118	-6.8349
4	1.0039	1.0266	1.0293	-9.61	-7.1119	-9.8015
5	1.0053	1.0247	1.0502	-8.61	-2.9278	-6.5778
6	1.0077	1.0247	1.0502	-7.95	-2.9278	-6.5778
7	0.997	1.0273	1.0413	-10.12	-7.0719	-6.532
8	0.996	1.0266	1.028	-10.62	-7.1119	-11.2744
9	1.0282	1.0247	1.0502	-10.32	-2.9278	-6.5778
10	1.0712	1.0247	1.0502	-5.43	-2.9278	-6.5778
11	1.0127	1.0247	1.0502	-6.28	-2.9278	-6.5778
12	1.0002	1.0002	1.0189	-6.24	-6.24	-6.6425
13	1.0143	1.0247	1.0502	-6.10	-2.9278	-6.5778
14	1.0117	1.0247	1.0502	-7.66	-2.9278	-6.5778
15	1.0154	1.0267	1.0327	-7.74	-7.1099	-5.7735
16	1.0318	1.0266	1.0374	-6.19	-7.1118	-5.7991
17	1.0336	1.0247	1.0502	-7.3	-2.9278	-6.5778
18	1.0309	1.0376	1.0486	-8.22	-6.4834	-6.2341
19	1.0499	1.0247	1.0502	-1.02	-2.9278	-6.5778
20	0.9912	1.0266	1.023	-2.01	-7.1119	-2.1984
21	1.0318	1.0268	1.0375	-3.78	-7.1022	-6.2966
22	1.0498	1.0247	1.0502	0.67	-2.9278	-6.5778
23	1.0448	1.027	1.0415	0.47	-7.0913	-5.8294
24	1.0373	1.0373	1.0324	-6.07	-6.07	-6.2361
25	1.0576	1.0272	1.0456	-4.36	-7.0788	-4.2966
26	1.0521	1.0489	1.0505	-5.53	-5.8364	-5.9709
27	1.0377	1.0267	1.042	-7.5	-7.1086	-3.7545
28	1.0501	1.0276	1.0476	-2.01	-7.0557	-3.5806
29	1.0499	1.0266	1.042	0.74	-7.1107	-2.7574
30	1.0475	1.0218	1.0668	-3.33	1.2003	-3.3341
31	0.982	1.0228	1.0388	0	1.2564	1.1465
32	0.9831	1.0228	1.0221	2.57	1.2564	4.2848
33	0.9972	1.0228	1.0165	4.19	1.2564	5.224
34	1.0123	1.0228	1.0314	3.17	1.2564	2.4426
35	1.0493	1.0228	1.0232	5.63	1.2564	4.0806
36	1.0635	1.0228	1.019	8.32	1.2564	4.6547
37	1.0278	1.0228	1.0173	2.42	1.2564	4.7816
38	1.0265	1.0228	1.0058	7.81	1.2564	7.6535
39	1.03	1.03	1.0053	-10.05	-10.05	-9.8038

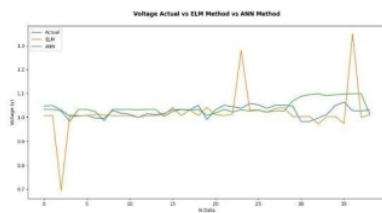

**Figure 6.** Graph of the actual voltage comparison between ELM and ANN

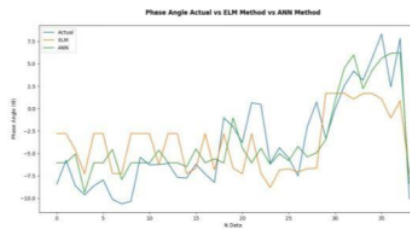

**Figure 7.** Graph of the phase angle comparison between ELM and ANN

## 5. Conclusion

The conclusions that can be obtained from this study from the use of the Extreme Learning Machine method to analyze the power flow on Bus 39-IEEE are: from the analysis of the flow of electric power carried out, the Extreme Learning Machine method was successfully used to analyze the flow of electric power or load flow. As for the accuracy of the prediction of the electric power flow analysis carried out by this method for MAE and MAPE, respectively, are 2.02 and 0.76%, because the MAPE value is <10%, accuracy of this method for electric power flow analysis is considered very good.

The analysis of the flow of electric power was carried out using parameters, namely the number of neurons as many as 5, the number of input and output each as much as 2, and the number of hidden layers as much as 1. Extreme Learning Machine method is able to complete the analysis of the flow of electric power with a very fast computation time of 0.010 seconds to execute the program from that method. While the Artificial Neural Network method is slower than ELM which takes 0.500 seconds to complete the analysis.

## References

- [1] Okakwu I K, Ogujor E A and P A Oriafio, 2017 *Load Flow Assessment of the Nigeria 330-kV Power System* **5** 4 159–165
- [2] Pandya K and Joshi S 2008 *J. Theor. Appl. Inf. Technol.* **4** 450–458
- [3] Sun Z L, Choi T M, Au K F and Yu Y 2008 *Decis. Support Syst.* **46** 1 411–419
- [4] Gunadin I C, Abdillah M, Soeprijanto, A and Penangsang O 2012 *WSEAS Trans. Power Syst.* **7** 3 91–103
- [5] Elsheikh A H, Sharshir S W, Elaziz M A, Kabeel A E, Guilan W and Haiou Z 2019 *Sol. Energy* **180** 622–639
- [6] Handika S, Gririantari I and Dharma A 2016 *Maj. Ilm. Teknol. Elektro*, **15** 1 84
- [7] Gunadin I C, Soeprijanto A and Penangsang O 2012 *Int. Rev. Electr. Eng.* **7** 3 4532–4537
- [8] Tanti D K 2012 *Int. J. Sci. Res. Publ.* **2** 11 1–6
- [9] Huang G B, Zhu Q Y and Siew C 2004 *Extreme learning machine: A new learning scheme of feedforward neural networks* **2**
- [10] Srimuang W and Intarasothonchun S 2015 *Proceedings of the 2015 12th International Joint Conference on Computer Science and Software Engineering, JCSSE 2015* 190–194
- [11] Perninge M and Hamon C 2013 *IEEE Trans. Power Syst.* **28** 1849–1857
- [12] Suryanto A A 2019 *Saintekbu* **11** 1 78–83
- [13] Lee Y W, Gaik T and Yee C Y 2018 *Int. J. Eng. Technol.* **7** 218–223
- [14] Pavol T, Vlkovic, O and Spendla L 2012 *Int. J. Comput. Theory Eng.* 144–147

ORIGINALITY REPORT

---

19%

SIMILARITY INDEX

14%

INTERNET SOURCES

8%

PUBLICATIONS

7%

STUDENT PAPERS

---

PRIMARY SOURCES

---

1	<a href="https://eprints.uniska-bjm.ac.id">eprints.uniska-bjm.ac.id</a> Internet Source	5%
2	<a href="https://www.coursehero.com">www.coursehero.com</a> Internet Source	2%
3	Basuki Rahmat, Endra Joelianto, I Ketut Eddy Purnama, Mauridhi Hery Purnomo. "ELM-Based Indonesia Vehicle License Plate Recognition System", E3S Web of Conferences, 2021 Publication	2%
4	<a href="https://d-nb.info">d-nb.info</a> Internet Source	1%
5	Tomoyuki Murakami. "Agent-based simulations of the influence of social policy and neighboring communication on the adoption of grid-connected photovoltaics", Energy Conversion and Management, 2014 Publication	1%
6	<a href="https://lib.unisayogya.ac.id">lib.unisayogya.ac.id</a> Internet Source	1%

---

7	Submitted to Ajman University of Science and Technology Student Paper	1 %
8	Submitted to Jawaharlal Nehru Technological University Student Paper	1 %
9	"Artificial Intelligence and Renewables Towards an Energy Transition", Springer Science and Business Media LLC, 2021 Publication	1 %
10	Guoqiang Li, Peifeng Niu. "An enhanced extreme learning machine based on ridge regression for regression", Neural Computing and Applications, 2011 Publication	1 %
11	jglobal.jst.go.jp Internet Source	1 %
12	Submitted to University of Queensland Student Paper	<1 %
13	ijesrt.com Internet Source	<1 %
14	Ali Keyhani, Mohammad N. Marwali, Min Dai. "Integration of Green and Renewable Energy in Electric Power Systems", Wiley, 2009 Publication	<1 %
15	eprints.glos.ac.uk Internet Source	

<1 %

16

[repository.unhas.ac.id](https://repository.unhas.ac.id)

Internet Source

<1 %

17

[www.ukessays.com](http://www.ukessays.com)

Internet Source

<1 %

18

K.K. Shukla, Raghunath. "An efficient global algorithm for supervised training of neural networks", Computers & Electrical Engineering, 1999

Publication

<1 %

19

Muhammad Ibnu Sa'ad, Kusri, M. Syukri Mustafa. "Student Prediction of Drop Out Using Extreme Learning Machine (ELM) Algorithm", 2020 2nd International Conference on Cybernetics and Intelligent System (ICORIS), 2020

Publication

<1 %

20

[deepai.org](https://deepai.org)

Internet Source

<1 %

21

[downloads.hindawi.com](https://downloads.hindawi.com)

Internet Source

<1 %

22

[mdpi.com](https://mdpi.com)

Internet Source

<1 %

23

[repository.ub.ac.id](https://repository.ub.ac.id)

Internet Source

<1 %

24

vdoc.pub  
Internet Source

<1 %

25

Lecture Notes in Computer Science, 2012.  
Publication

<1 %

26

Roy Orenge, M Christopher Maina, George N. Nyakoe. "Optimal Sizing and Placement of Solar Photovoltaic Based DGs in the IEEE 9 Bus System Using Particle Swarm Optimization Algorithm", 2018 IEEE PES/IAS PowerAfrica, 2018  
Publication

<1 %

Exclude quotes Off

Exclude matches Off

Exclude bibliography On